

### 40Gb/s QSFP+ SR4 Optical Transceiver

#### 40G-Q-SR4

##### ■ Product Features

- ✓ 4 independent full-duplex channels Up to 10.5Gbps data rate per channel
- ✓ MTP/MPO optical connector
- ✓ Capable of over 150m transmission on OM4 multi-mode ribbon fiber
- ✓ Single +3.3V power supply
- ✓ QSFP+ MSA compliant
- ✓ Operating case temperature: 0~70°C
- ✓ RoHS compliant
- ✓ Compliant with IEEE802.3ba
- ✓ Compliant with QSFP+ MSA: SFF-8436



##### ■ Applications

- ✓ 40G Ethernet
- ✓ Infiniband 4X SDR DDR QDR
- ✓ 40G Telecom Connections

##### ■ General

Fiberend's 40G-Q-SR4 transceiver modules are designed for use in 40 Gigabit per second links over parallel multimode fiber, including breakout to four 10 Gigabit per second links.

They are compliant with the QSFP+ MSA and IEEE 802.3ba 40GBASE-SR4 and compatible with IEEE 802.3ae 10GBASE-SR. The optical transceiver is compliant per the RoHS Directive 2011/65/EU. They are RoHS compliant and lead-free.

##### ■ Product Selection

Part Number	Operating Case temperature	DDMI
40G-Q-SR4	Commercial (0~70°C)	Yes

##### ■ Regulatory Compliance

- ESD to the Electrical PINs: compatible with MIL-STD-883E Method 3015.7
- Immunity compatible with IEC 61000-4-3
- EMI compatible with FCC Part 15 Class B EN55022 Class B (CISPR 22B) VCCI Class B
- Laser Eye Safety compatible with FDA 21CFR 1040.10 and 1040.11 EN60950, EN (IEC) 60825-1,2
- RoHS compliant with RoHS 2 (2011/65/EU)

### ■ Pin Descriptions

Pin	Symbol	Name/Description	Ref.
1	GND	Ground	1
2	Tx2n	Transmitter Inverted Data Input	
3	Tx2p	Transmitter Non-Inverted Data output	
4	GND	Ground	1
5	Tx4n	Transmitter Inverted Data Input	
6	Tx4p	Transmitter Non-Inverted Data output	
7	GND	Ground	1
8	ModSelL	Module Select	
9	ResetL	Module Reset	
10	VccRx	+ 3.3V Power Supply Receiver	2
11	SCL	2-Wire Serial Interface Clock	
12	SDA	2-Wire Serial Interface Data	
13	GND	Ground	
14	Rx3p	Receiver Non-Inverted Data Output	
15	Rx3n	Receiver Inverted Data Output	
16	GND	Ground	1
17	Rx1p	Receiver Non-Inverted Data Output	
18	Rx1n	Receiver Inverted Data Output	
19	GND	Ground	1
20	GND	Ground	1
21	Rx2n	Receiver Inverted Data Output	
22	Rx2p	Receiver Non-Inverted Data Output	
23	GND	Ground	1
24	Rx4n	Receiver Inverted Data Output	1
25	Rx4p	Receiver Non-Inverted Data Output	
26	GND	Ground	1
27	ModPrsL	Module Present	
28	IntL	Interrupt	

29	VccTx	+3.3 V Power Supply transmitter	2
30	Vcc1	+3.3 V Power Supply	2
31	LPMODE	Low Power Mode	
32	GND	Ground	1
33	Tx3p	Transmitter Non-Inverted Data Input	
34	Tx3n	Transmitter Inverted Data Output	
35	GND	Ground	1
36	Tx1p	Transmitter Non-Inverted Data Input	
37	Tx1n	Transmitter Inverted Data Output	
38	GND	Ground	1

**Notes:**

1. GND is the symbol for signal and supply (power), Connect these directly to the host board signal common ground plane
2. VccRx, Vcc1 and VccTx are the receiving and transmission power suppliers and shall be applied concurrently. Vcc Rx, Vcc1 and Vcc Tx may be internally connected within the QSFP+, The connector pins are each rated for a maximum current of 500mA.

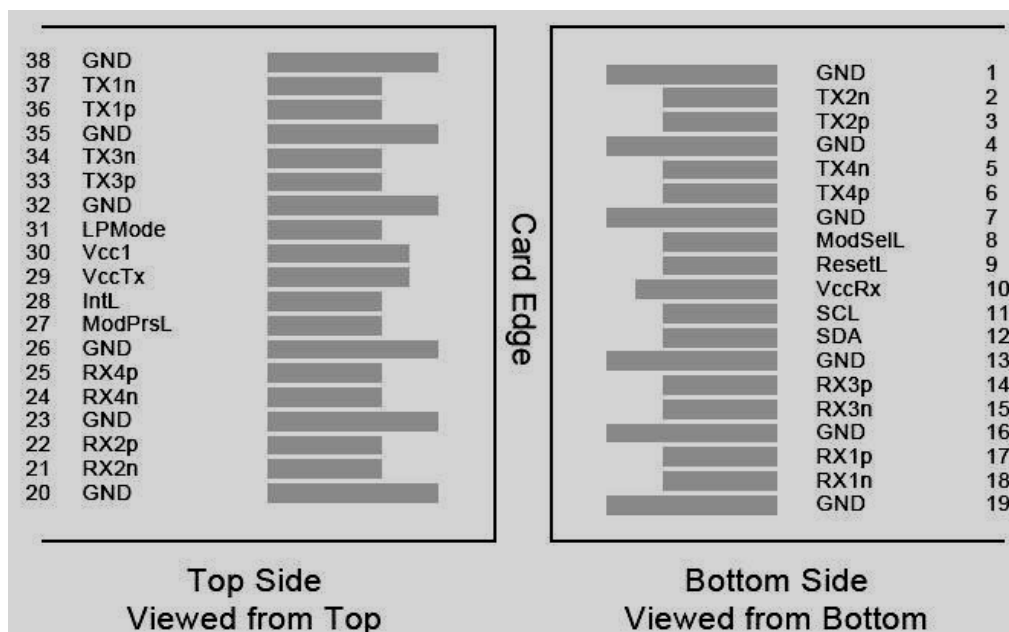

**QSFP Transceiver Electrical Pad Layout**

### ■ Optical Interface Lanes and Assignment

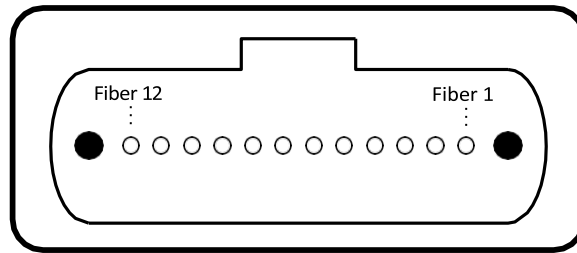

Outside view of the QSFP+ module MPO

### Lane Assignment

Fiber #	Lane Assignment
1	RX0
2	RX1
3	RX2
4	RX3
5	Not used
6	Not used
7	Not used
8	Not used
9	TX3
10	TX2
11	TX1
12	TX0

### ■ Recommend Circuit Schematic

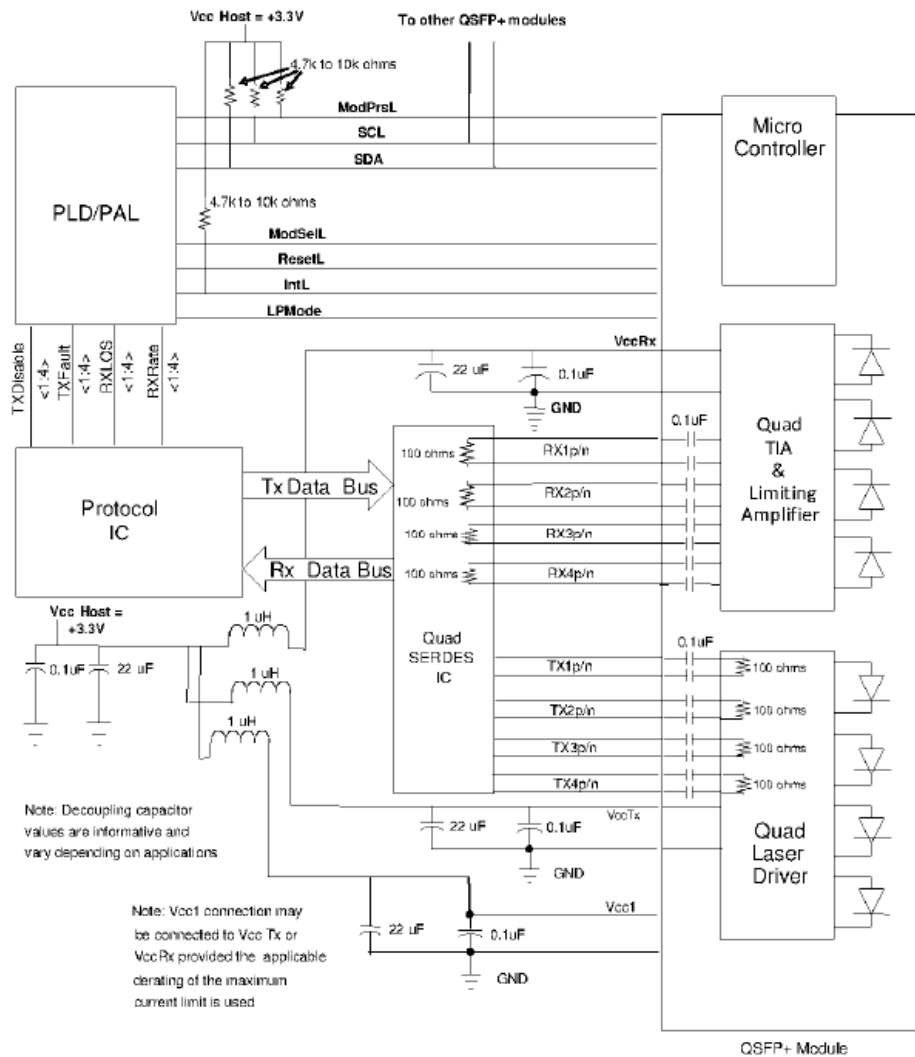

### Absolute Maximum Ratings

Parameter	Symbol	Min	Typ	Max	Unit	Ref.
Maximum Supply Voltage	Vcc	-0.5		+4.0	V	
Storage Temperature	TS	-40		+85	°C	
Operating Humidity	RH	0		85	%	

### Recommended Operating Conditions

Parameter	Symbol	Min	Typ	Max	Unit	Ref.
Power Supply Voltage	Vcc	3.13	3.30	3.47	V	
Power Supply Current	Icc			432	mA	
Case Operating Temperature	Tc	0		+70	°C	
Bit Rate per Lane	Br	1062		10500	Mbps	

Link distance on OM3 MMF	Dmax	-	-	100	m	
Link distance on OM4 MMF	Dmax			150	m	

### ■ Electrical Characteristics (TOP=25°C, Vcc=3.3Volts)

Parameter	Symbol	Min	Typ	Max	Unit	Ref.
Data Rate, each Lane		1		10.5	Gbps	
Control I/O Voltage, High	VIH	2.0		VCC	V	
Control I/O Voltage, Low	VIL	0		0.7	V	
Inter-Channel Skew	TSK			150	ps	
RESETL Duration			10		us	
RESETL De-assert time				2000	ms	
Power on time				2000	ms	
<b>Transmitter (XLPP1)</b>						
Single Ended Output Voltage Tolerance		-0.3		4	V	
AC Common mode Voltage Tolerance (RMS)		15			mV	
Tx Input Diff Voltage	Vi	90		1600	mV	
Tx Input Diff Impedance	Zi	80	100	120	Ω	
Differential Input Return Loss		See IEEE 802.3ba 86A.4.11			dB	
J2 Jitter Tolerance	Jt2	0.17			U I	
J9 Jitter Tolerance	Jt9	0.29			U I	
Data Dependent Pulse Width Shrinkage	DDPWS	0.07			U I	
Eye Mask Coordinates {X1, X2,Y1, Y2}		0.11,0.31 95,350			U I mV	
<b>Receiver (XLPP1)</b>						
Single Ended Output Voltage Tolerance1		-0.3		4	V	
AC Common mode Voltage Tolerance (RMS)				7.5	mV	
Termination Mismatch at 1MHz				5	%	
Differential Output Return Loss		See IEEE 802.3ba 86A.4.2.1			dB	
Common-mode Output Return Loss		See IEEE 802.3ba 86A.4.2.2			dB	

Rx Output Diff Voltage	Vo		600	800	mV	
Rx Output Rise and Fall Time	Tr/Tf			35	ps	
J2 Jitter Tolerance	Jr2			0.46	UI	
J9 Jitter Tolerance	Jr9			0.65	UI	
Eye Mask Coordinates {X1, X2, Y1, Y2}			0.29, 0.5 150, 425		UI mV	

### ■ Optical Characteristics (TOP=25°C, Vcc=3.3 Volts)

Parameter	Symbol	Min	Typ	Max	Unit	Note
<b>Transmitter</b>						
Center Wavelength	$\lambda_t$	840	850	860	nm	
RMS Spectral Width	Pm			0.65	nm	
Average Optical Power, each Lane	Pavg	-7.6	-2.5	+2.4	dBm	
Optical Modulation Amplitude (OMA)	Poma	-6		+3	dBm	
Peak Power, each Lane	PPt			4	dBm	
Launch Power in OMA minus Transmitter and Dispersion Penalty (TDP), each Lane		-7			dB	
TDP, each Lane				4	dB	
Extinction Ratio	ER	3			dB	
Relative Intensity Noise	Rin			-128	dB/Hz	12dB reflection
Optical Return Loss Tolerance				12	dB	
Encircled Flux			>86% at 19um <30% at 4.5um			
Transmitter Eye Mask Definition {X1, X2, X3, Y1, Y2, Y3}		0.23, 0.34, 0.43, 0.27, 0.33, 0.4				
Average Launch Power OFF Transmitter, each Lane	Poff			-30	dBm	
<b>Receiver</b>						
Center Wavelength	$\lambda_r$	840		860	nm	
Damage Threshold	THd	2.4			dBm	

Average Power at Receiver Input, each Lane		-9.5		2.4	dBm	
Receiver Reflectance				-12	dB	
OMA, each Lane				3	dBm	
Stressed Receiver Sensitivity in OMA, each Lane		-7.5			dBm	
Peak Power, each Lane	PPr			4	dBm	
Los Assert	LosA	-30			dBm	
Los Dessert	LosD			-12	dBm	
Los Hysteresis	LosH	0.5			dB	

### ■ Mechanical Specifications

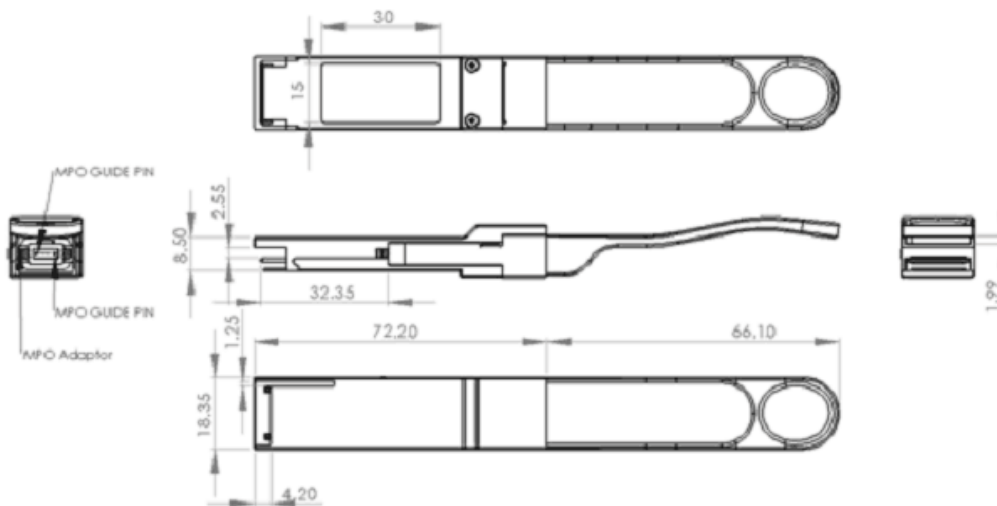

**40G-Q-SR4(dimensions are in mm)**



### ■ EEPROM Information

EEPROM memory map specific data field description is as below:

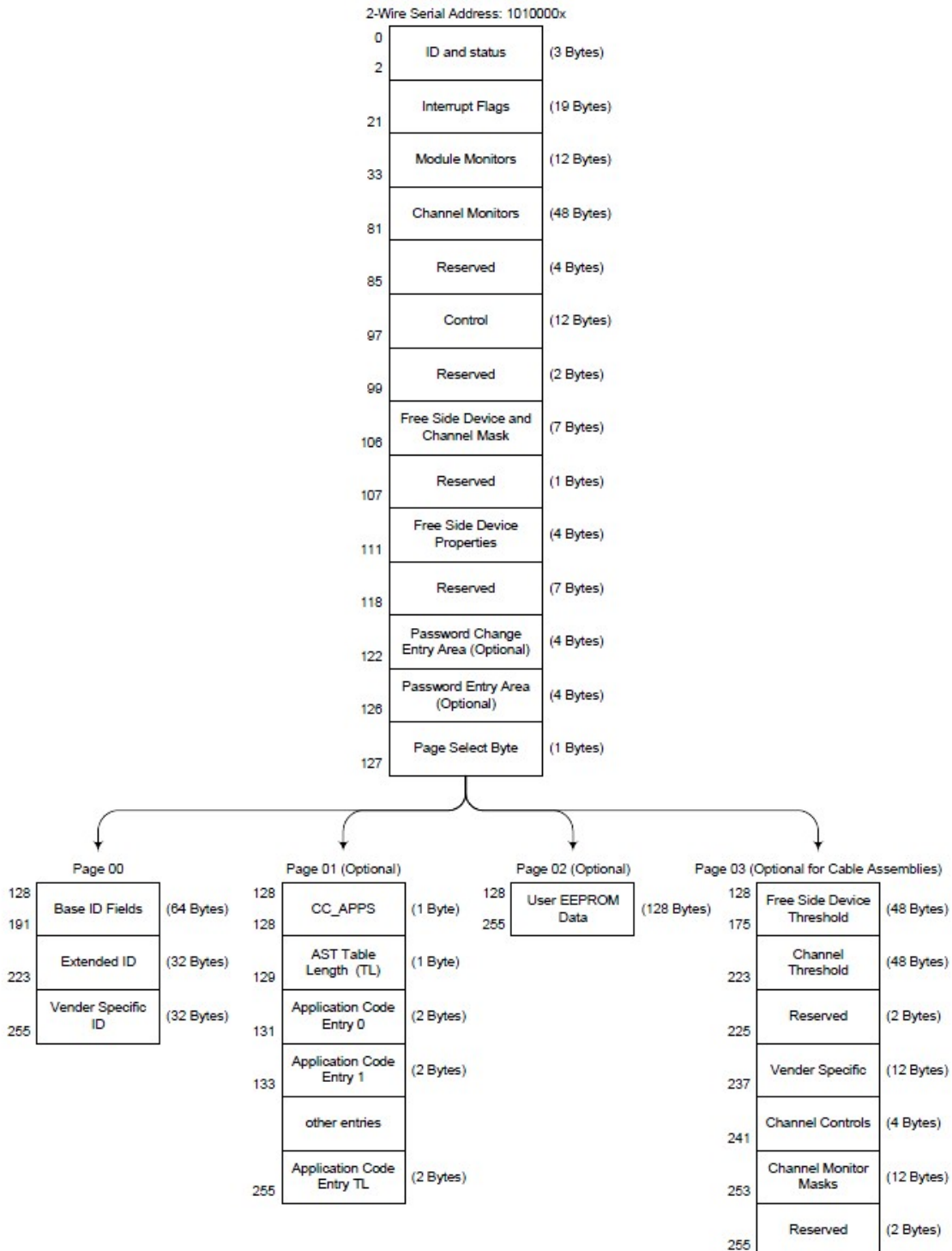

### ■ Digital Diagnostic Monitoring Interface

Five transceiver parameter values are monitored. The following table defines the monitored parameter's accuracy.

<b>Parameter</b>	<b>Range</b>	<b>Accuracy</b>	<b>Calibration</b>
Temperature	0 to +70°C (C)	±3°C	Internal
Voltage	2.97 to 3.63V	±3%	Internal
Bias Current	0 to 100mA	±10%	Internal
RX Power	-12 to 2.5dBm	±2dB	Internal